

# Erdgreifer für Bagger 1,5 > 16 t

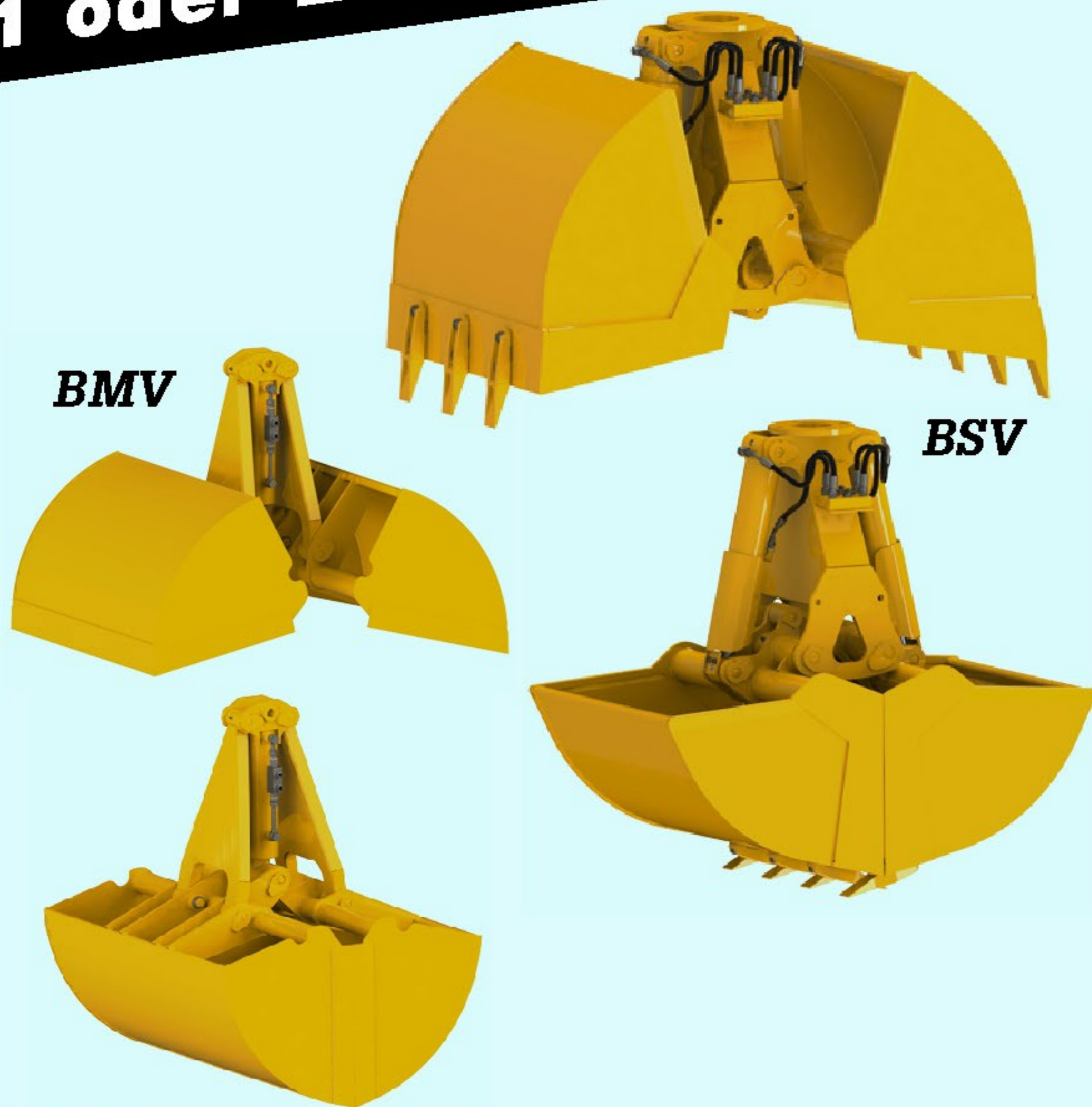

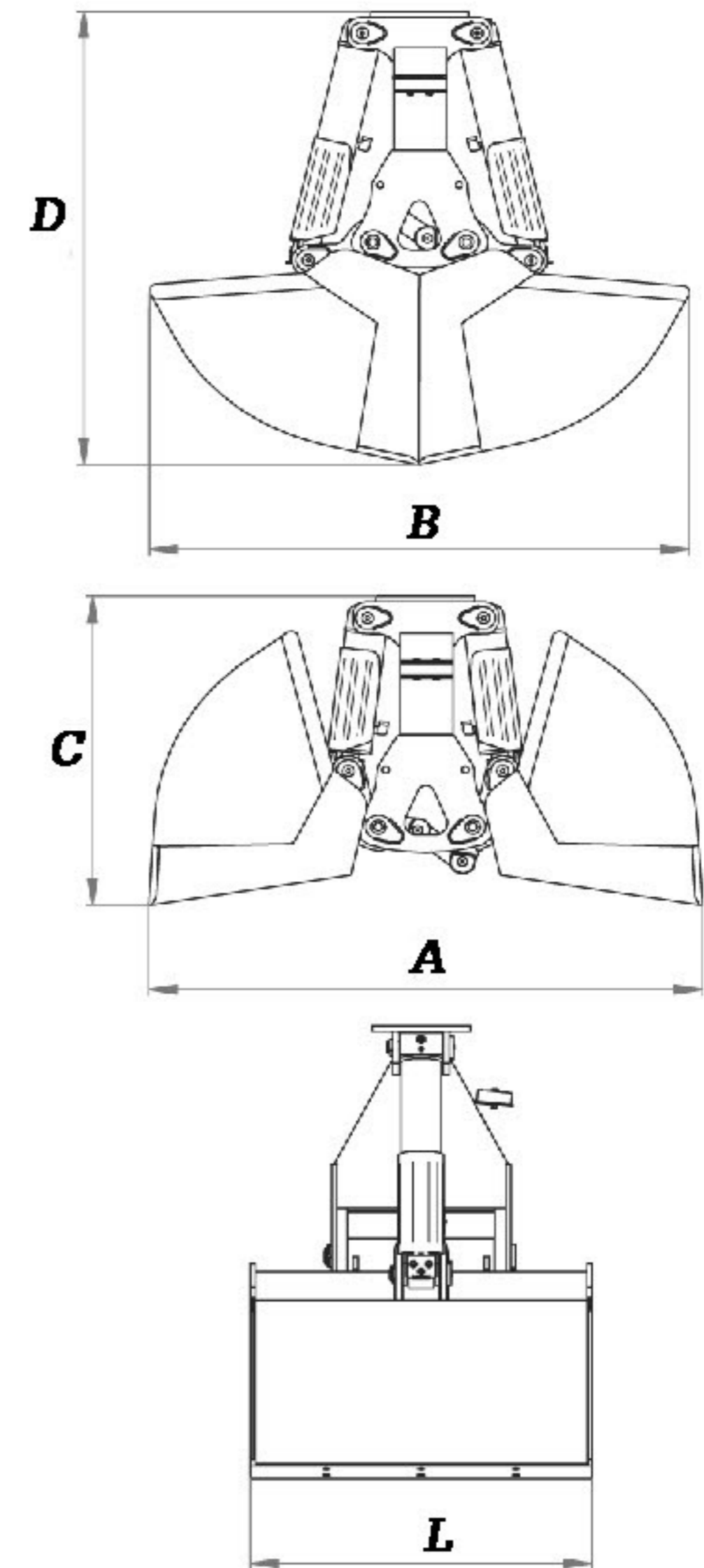

## 1 oder 2 stehende Zylinder



Benne preneuse avec deux cylindres  
 Benne bivalente pesante con due cilindri

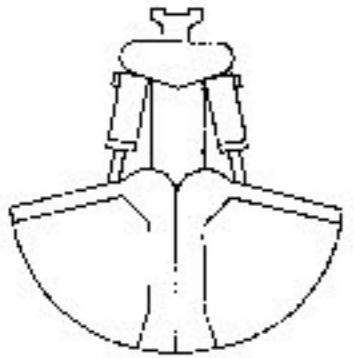

Edition 3-20

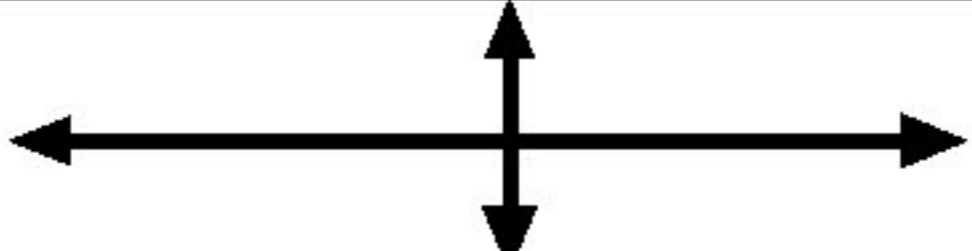
									
					A	B	C	D	L
<b>BMV 55</b>	<b>55</b>	<b>220</b>	<b>75</b>	<b>400</b>	<b>730</b>	<b>590</b>	<b>660</b>	<b>770</b>	<b>500</b>
<b>BMV100</b>	<b>100</b>	<b>220</b>	<b>130</b>	<b>500</b>	<b>1100</b>	<b>850</b>	<b>950</b>	<b>1165</b>	<b>430</b>
<b>BMV155</b>	<b>150</b>	<b>220</b>	<b>152</b>	<b>600</b>	<b>1100</b>	<b>850</b>	<b>950</b>	<b>1165</b>	<b>630</b>
<b>BMV200</b>	<b>200</b>	<b>220</b>	<b>240</b>	<b>1000</b>	<b>1370</b>	<b>1020</b>	<b>1010</b>	<b>1280</b>	<b>630</b>
<b>BMV300</b>	<b>300</b>	<b>220</b>	<b>260</b>	<b>1000</b>	<b>1370</b>	<b>1020</b>	<b>1010</b>	<b>1280</b>	<b>830</b>
<b>BMV400</b>	<b>400</b>	<b>220</b>	<b>280</b>	<b>1200</b>	<b>1370</b>	<b>1020</b>	<b>1010</b>	<b>1280</b>	<b>1030</b>
<b>BMV500</b>	<b>500</b>	<b>220</b>	<b>300</b>	<b>1500</b>	<b>1370</b>	<b>1020</b>	<b>1010</b>	<b>1280</b>	<b>1230</b>
<b>BSV 50</b>	<b>50</b>	<b>250</b>	<b>210</b>	<b>1500</b>	<b>905</b>	<b>910</b>	<b>750</b>	<b>960</b>	<b>270</b>
<b>BSV140</b>	<b>140</b>	<b>250</b>	<b>270</b>	<b>2000</b>	<b>1350</b>	<b>1260</b>	<b>860</b>	<b>1190</b>	<b>270</b>
<b>BSV240</b>	<b>240</b>	<b>250</b>	<b>315</b>	<b>2000</b>	<b>1350</b>	<b>1260</b>	<b>860</b>	<b>1190</b>	<b>510</b>
<b>BSV250</b>	<b>250</b>	<b>250</b>	<b>320</b>	<b>1500</b>	<b>1280</b>	<b>1300</b>	<b>800</b>	<b>1145</b>	<b>500</b>
<b>BSV300</b>	<b>300</b>	<b>250</b>	<b>346</b>	<b>1500</b>	<b>1280</b>	<b>1300</b>	<b>800</b>	<b>1145</b>	<b>600</b>
<b>BSV400</b>	<b>410</b>	<b>250</b>	<b>315</b>	<b>1500</b>	<b>1280</b>	<b>1300</b>	<b>800</b>	<b>1145</b>	<b>800</b>
<b>BSV500</b>	<b>530</b>	<b>250</b>	<b>345</b>	<b>1500</b>	<b>1280</b>	<b>1300</b>	<b>800</b>	<b>1145</b>	<b>1000</b>